



**NTF**  
A A L B O R G  
ntf.dk

**Stainless steel  
designed for  
your benefit**

**Zulieferprogramm**



## Zulieferprogramm

NTF produziert Ganz- und Halbfabrikate nach Kundenwunsch, hauptsächlich aus rostfreiem Draht und Rundstahl.



Das Produkt kann z. B. wie folgt sein:

- *Gitter aus rostfreiem Stahl*
- *Drahtausrichtung*
- *Drahtnetz/CNC-Schweissen*
- *Drahtnetz in Rollen – geschweisst oder gewebt.*

## Biegen in 3D

Biegeteile werden nach Kundenwunsch auf CNC-gesteuerten 3D Biegemaschinen hergestellt. Drahtbiegen und Ausrichten direkt von der Rolle.



- *Kein Verlust*
- *Gleichbleibende Qualität*
- *3D – Rundstahlbiegung von der Rolle in 3 mm bis 12 mm*

# Gundsätze für das 3D Biegen

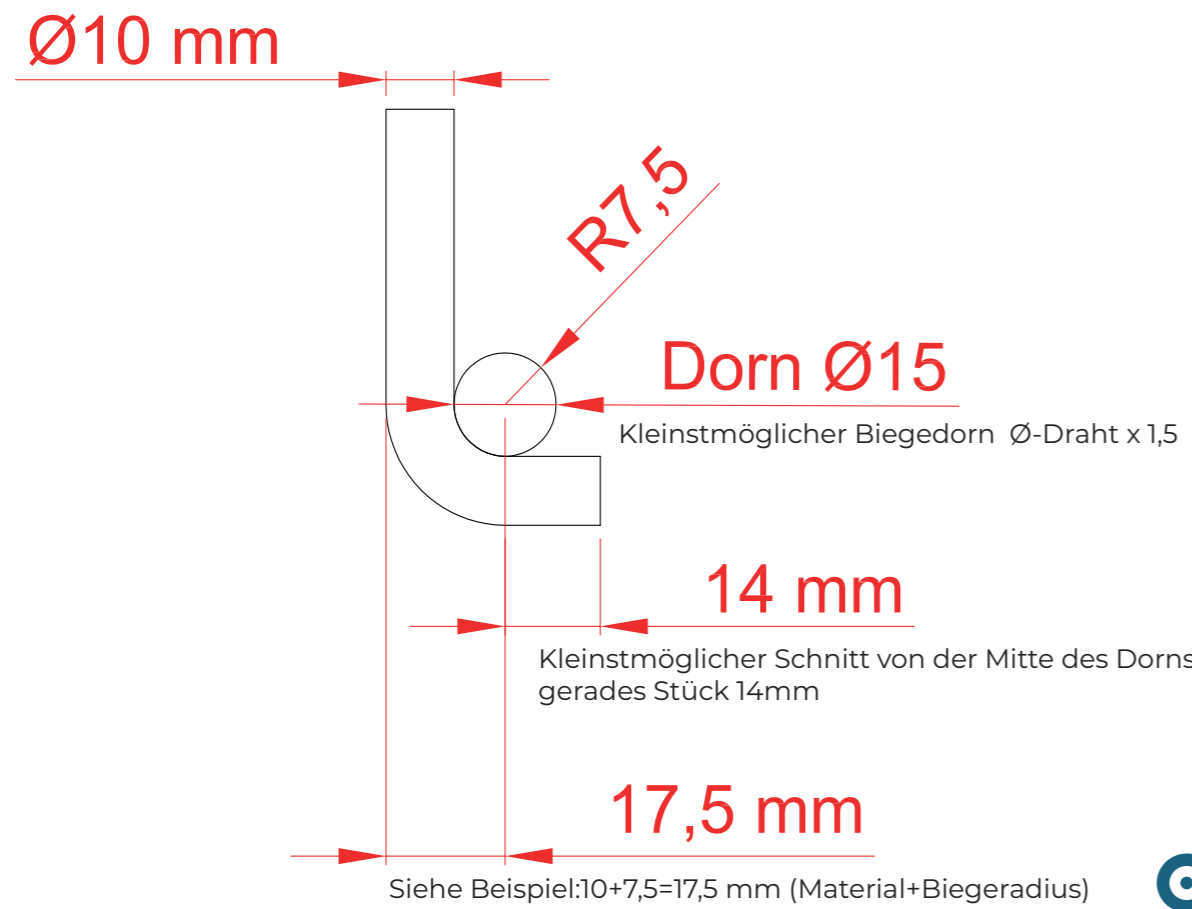

# Möglichkeiten von Abschlüssen



1) Gerade gekappt mit minimalem Grat.



2) Gefastetes Ende.



3) Gebürstetes Ende.

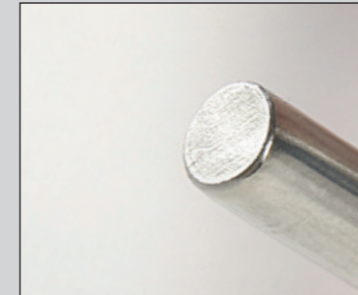

4) Gefastetes und gebürstetes Ende.



5) Rundkuppe, mechanisch.



6) Soft-Ende. Geschweisst.



7) CNC-gefast, mechanisch, aussen glatt, innerer Grat.



8) CNC-V-Rille, mechanisch.



9) Gewindeende.

## Drachtnetze / CNC - Schweissen

Drahtnetze können auf Kundenwunsch in Fix-Massen hergestellt werden. NTF besitzt moderne Maschinen zum Punktschweissen und für Spezialaufgaben. Eigenproduktion von lagergeführten, geschweissten Standardnetzen.

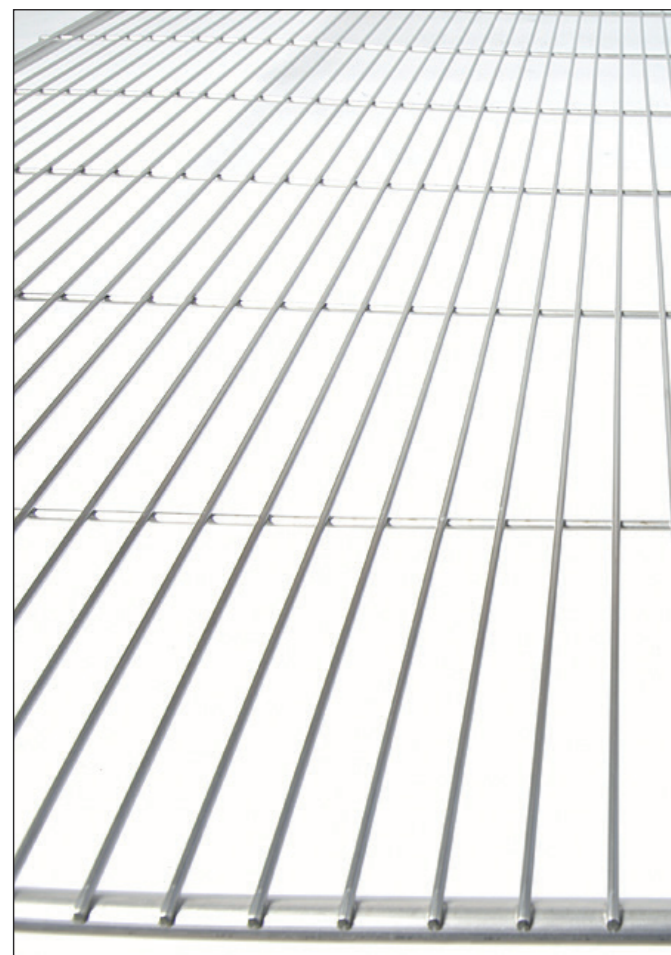
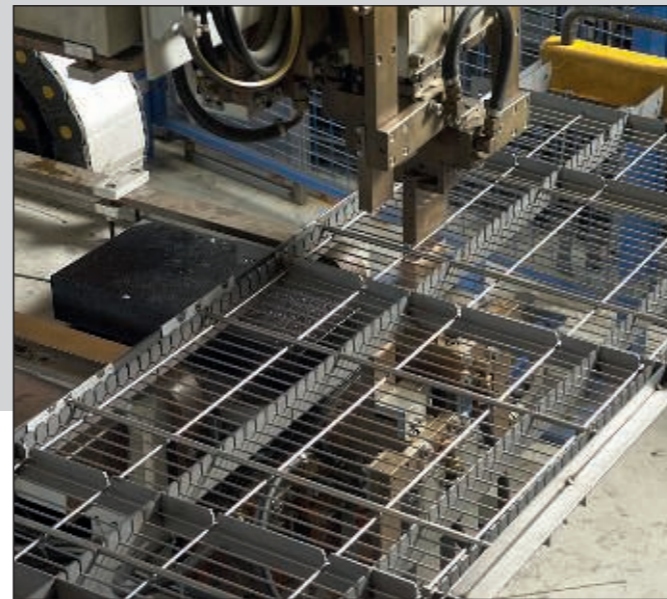

Weiterhin ist eine Auswahl von Drahtnetzen in Rollen, geschweisst oder gewebt, am Lager.





**Stainless steel  
designed for  
your benefit**

**NTF-Aalborg A/S  
Hagensvej 17  
DK-9530 Støvring**

**Telefon: +45 98 37 37 66  
Fax: +45 98 37 37 51  
Mail: [mail@ntf.dk](mailto:mail@ntf.dk)  
Web: [www.ntf.dk](http://www.ntf.dk)**

