

NTF Aalborg

Stainless steel designed for your benefit!

www.ntf.dk



Subcontractor work

GB

2

Subcontractor work

NTF produces finished and semi-finished products according to customer specifications, with focus on stainless steel wire and round steel. Subcontractor work can consist of:

- Stainless steel grating
- Bent items produced by CNC-controlled 3D bending machine
- Wire straightening
- Woven or CNC welded wire net
- Net in roles - both welded and woven

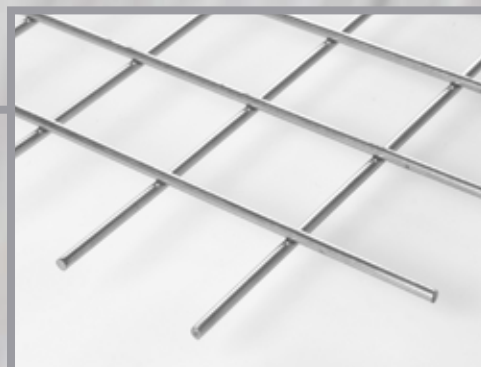

3D Round steel bending

Bending items are made according to customer specifications on a CNC-controlled 3D bending machine. Wire bending and wire straightening directly from coil.

- No waste
- Consistent quality
- 3D Round Steel bending from coil in \varnothing 3 mm - 12 mm

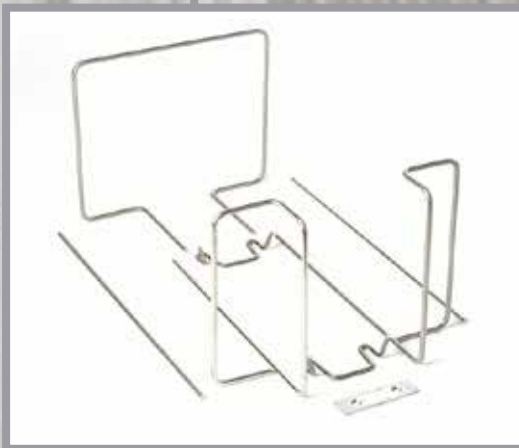

RULE OF THUMB 3D BENDING

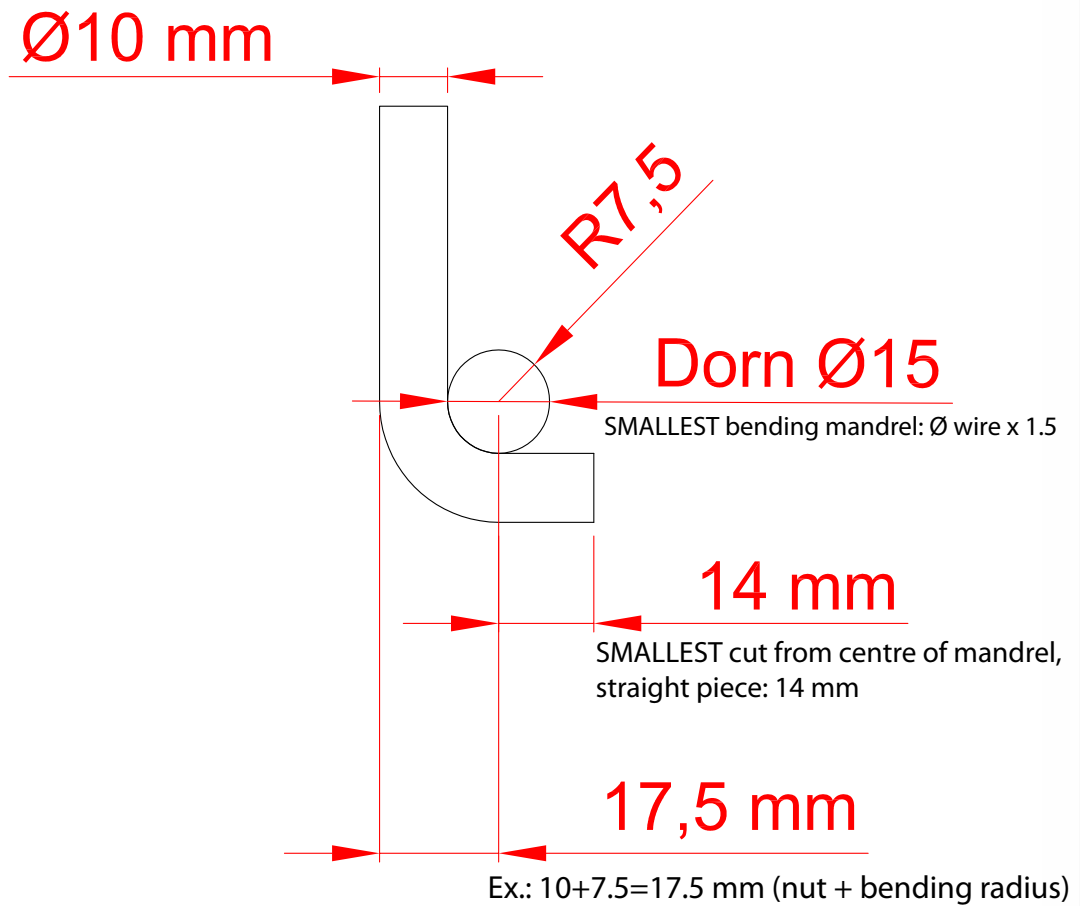

End finishes



1) Straight cut with minimal burr.

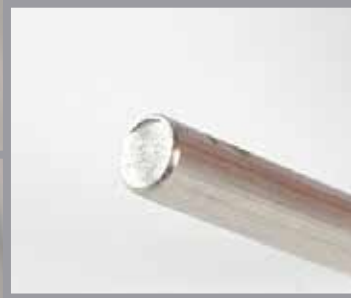

2) Chamfered end.



3) Brushed end.



4) Chamfered and brushed end.



5) Mechanically rounded end.



6) Soft end – melted.



7) V-chamfering CNC. Mechanical. Smooth outside. Burr inside.



8) V-groove CNC. Mechanical. For locking ring, embedment or similar.



9) Threaded end.



Wire net/CNC welding

Wire net is manufactured in fixed dimensions according to customer specifications. NTF have modern equipment at its disposal for spot welding of special tasks. We have our own production of welded standard nets, on stock.

Furthermore, we keep a range of nets in rolls - both welded and woven in stock.

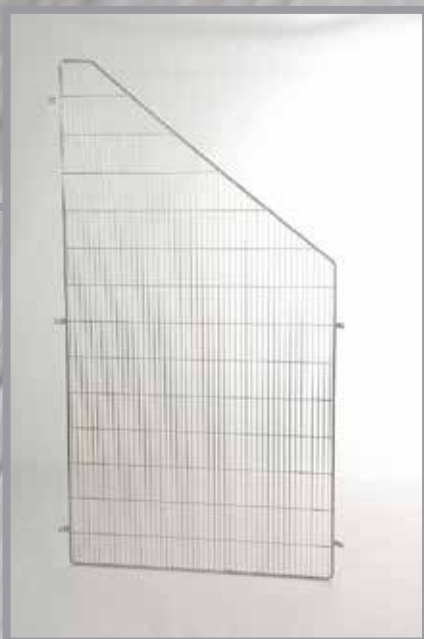





NTF-Aalborg A/S

Hagensvej 17
DK-9530 Støvring

Phone: +45 98 37 37 66

Fax : +45 98 37 37 51

Email: mail@ntf.dk

Web: www.ntf.dk



Stainless steel designed for your benefit!