

Support Leg Mounting Guide

1: Mounting of post bracket

Replace the M8x16 Flange bolts on the net with the Pos. 7 Flange bolts, and remount with Pos 1. Post bracket bracket. Mount the "long" bracket (Pos 2) according to the view beneath

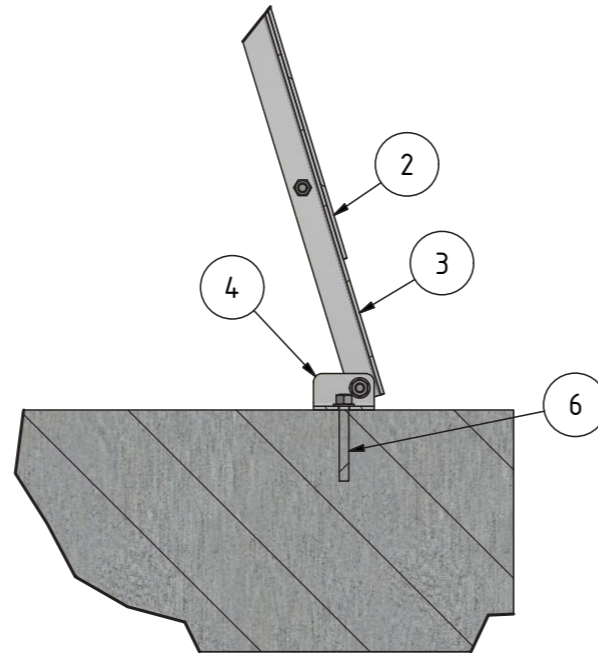
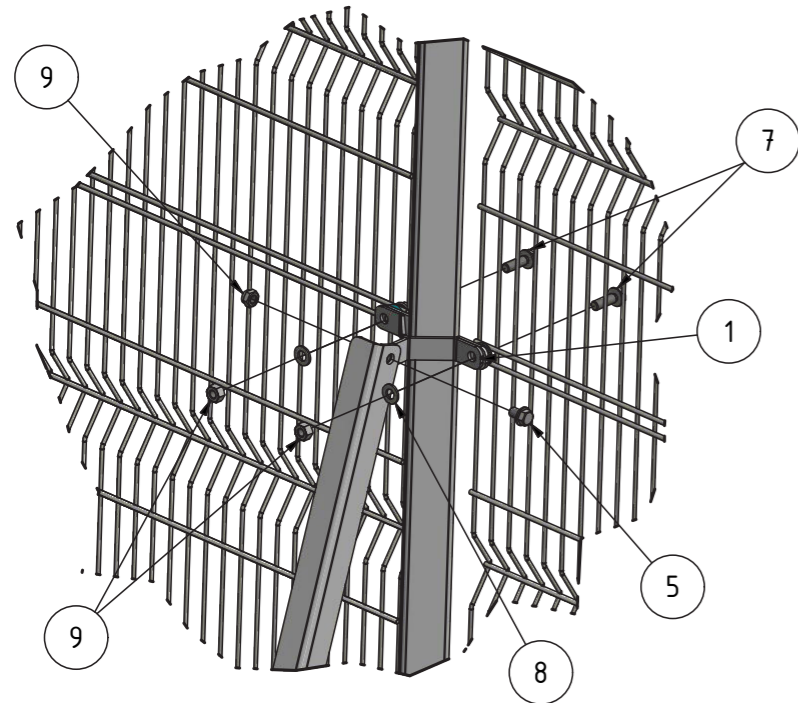

3: Mounting of ground bracket

1. Mark up hole.
2. Drill the hole.
- 3: Mount Pos. 4 ground bracket by using Pos. 6 expansion bolt.
4. Mount Pos 4. with the included washer and hex nut.

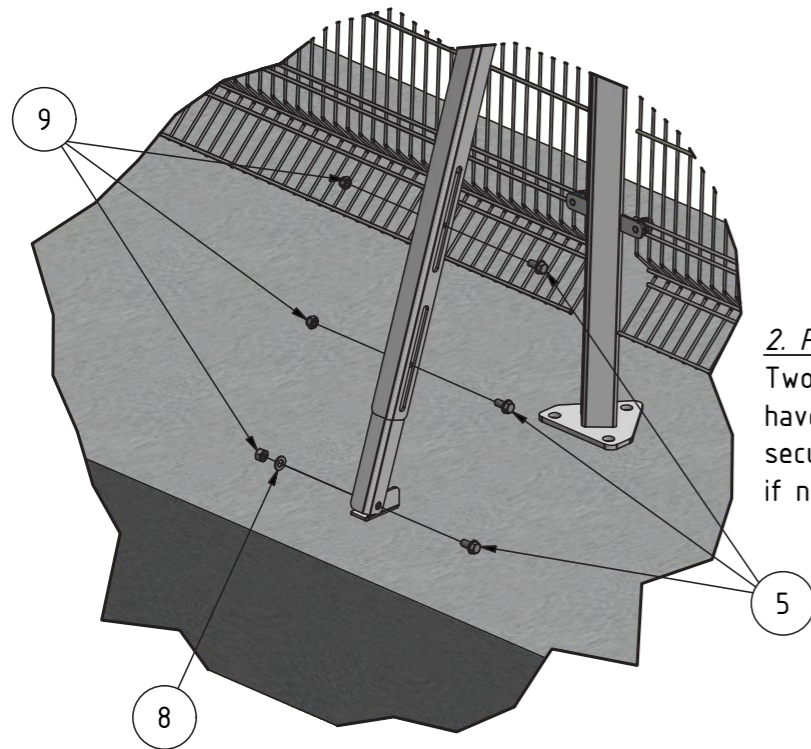
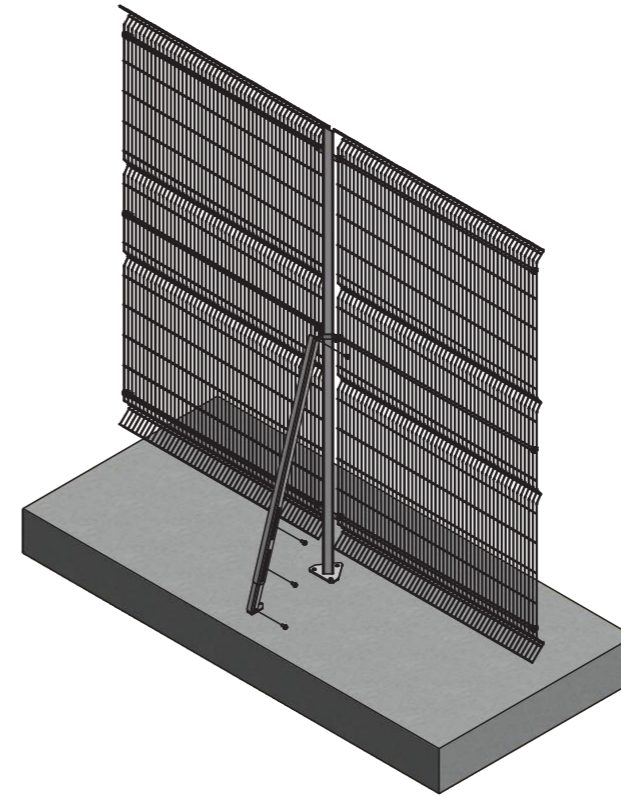

2. Post support leg assembly

Two additional lock nuts have been added to secure the two Pos. 5 Bolts additionally if need arises, they can be excluded

PARTS LIST			
ITEM	QTY	PART NUMBER	DESCRIPTION
1	1	A003-235-1	Post bracket
2	1	A003-235-2	Bracket "Long"
3	1	A003-235-3	Bracket "short"
4	1	A003-235-4	Ground bracket
5	4	M001-289	M8 x 16 Flange bolt
6	1	M001-071	Expansion bolt - M8 (Washer and nut included)
7	2	M005-289	M8 x 25 Flange bolt
8	3	M001-196	M8 washer
9	6	M001-197	M8 lock Nut